



# ATV Solutions



## ASSEMBLY INSTRUCTIONS FOR TILT-A-RACK® MODELS 350RV, 350RV MINI, 500RV, 500ATV, AND 700RV.

### HERE'S WHAT YOU RECEIVED:

- (2) Hinge-Pins
- (1) Bent Hitch-Pin
- (4) Roll-Pins (black)
- (1) 15/16" x 4" bolt & nut
- (3) Carrier Assemblies



### HERE'S WHAT YOU'LL NEED:

- Hammer
- 1/2" Drive Ratchet
- 15/16" Socket
- 15/16" Wrench



### IMPORTANT NOTES:

Although our carriers can be assembled by one person, we highly recommend that you have a helper.

Since our carriers have a thick galvanized coating for years of longevity, some of the bolt holes may be too tight, due to the coating, to easily insert your bolts. This is easily remedied by lightly tapping the bolt into it's respective bolt hole. *(See photo to right.)*

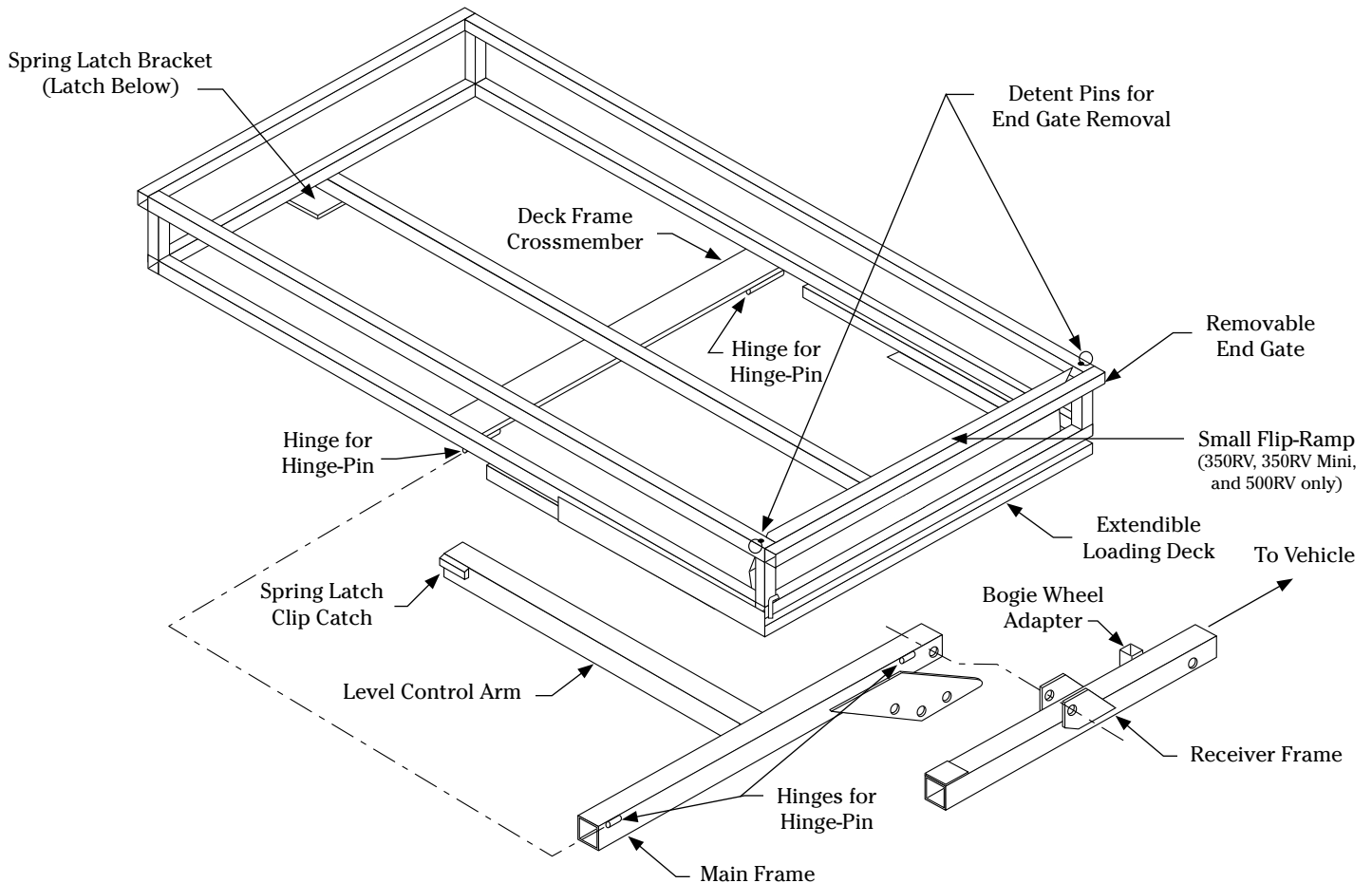

**IF YOU HAVE QUESTIONS REGARDING THE ASSEMBLY OF THIS UNIT,  
OR HAVE MISSING PARTS, PLEASE CALL 1-866-777-9727.**

**ATV Solutions also carries a wide selection of accessories for your new carrier!**

Custom tie-downs, covers, hitch adapters, Bogie Wheels, and more, we've got what you need to **LOAD and GO!**

Go to [www.ATVSolutions.com](http://www.ATVSolutions.com) or call 1-866-777-9727 for more information.



**STEP 1**

Insert Receiver Frame into the Main Frame.



**STEP 2**

Secure the Receiver Frame to Main Frame using the 15/16" x 4" Bolt with self-locking nut.



**STEP 3**

Insert the 5/8" bent hitch-pin in this location for installation onto your vehicle. Then insert spring-clip into the hitch-pin.

— Turn the main rack-unit upside down for Steps 4 - 9. —



**STEP 4**

Turn your Main Frame Assembly upside down and align the Roll-Pin Hinges on the Main Frame Assembly to the Roll-Pin Hinges on the Metal Deck. Refer to the diagram on Page 1 for Hinge locations.



**STEP 5**

Insert Hitch-Pin into the hinge on the underside of the Metal Deck. A hammer will be useful for this step.

**STEP 6**

Use a hammer and gently tap a small black Roll-Pin into each appropriate hole on your Hitch-Pin to ensure that it stays in place during the use of your carrier.



**STEP 7**

Repeat Steps 5 & 6 and insert the second Hitch-Pin onto the underside of the Metal Deck. Then tap both Roll-Pins into place on the Hinge Pin.



**STEP 8**

With the Main Frame Assembly attached to the Metal Deck, you can now secure it using the bent hitch-pin that is included on the Main Frame.



**STEP 9**

Your completed assembly should now look like this when still upside down. Turn the assembly over and install in your vehicles receiver, secure it with your hitch-pin and you're almost ready to LOAD and GO!

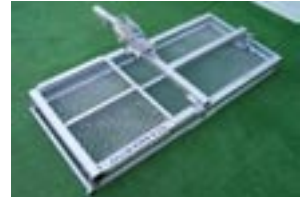

**STEP 10**

When you install the carrier on your vehicle, tighten or loosen the Leveling Bolt, located on the underside of the Main Frame Assembly, to level the deck on your vehicle. (Shown upside down)



**OPERATING INSTRUCTIONS FOR TILT-A-RACK®**

**MODELS 350RV, 350RV MINI, 500RV, 500ATV, AND 700RV.**

**STEP 1**

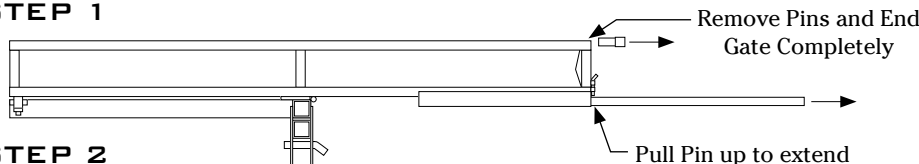

**STEP 2**

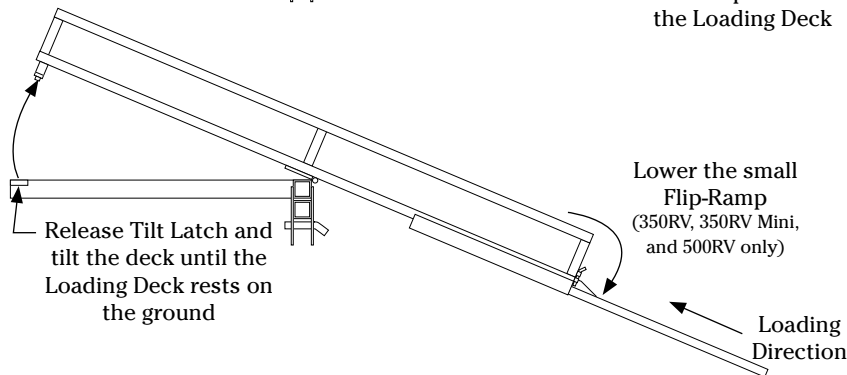

**STEP 3 - LOAD YOUR UNIT AND GO!**

**IF YOU HAVE QUESTIONS REGARDING THE ASSEMBLY OF THIS UNIT, OR HAVE MISSING PARTS, PLEASE CALL 1-866-777-9727.**

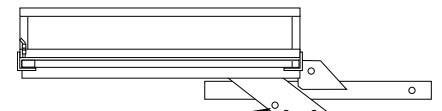

Pin location for installing to your vehicle

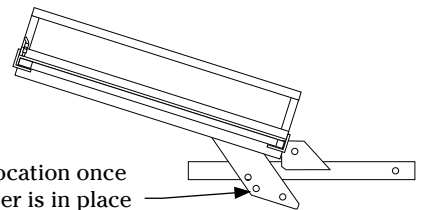

Pin location once Scooter is in place and ready for travel

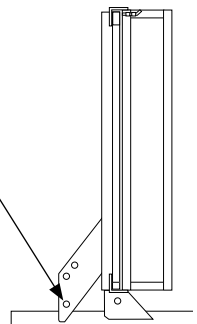

Pin location for vertical storage to eliminate the extra length without removing rack from vehicle