

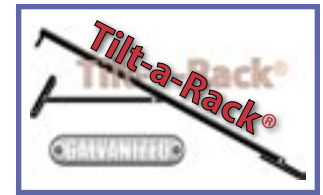

ATV Solutions



ASSEMBLY INSTRUCTIONS FOR TILT-A-RACK® MODEL 410CR.

HERE'S WHAT YOU RECEIVED:

- (1) Hinge-Pins
- (2) Roll-Pins (Black)
- (1) 9/16" x 6" bolt & nut
- (4) 9/16" x 3" bolt & nut
- (2) 1/2" x 1 3/4" bolt & nut
- (4) Carrier Assemblies

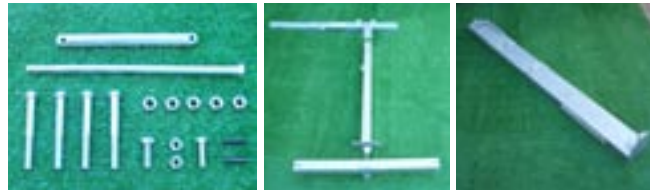

(Shown upside down)

HERE'S WHAT YOU'LL NEED:

- Hammer
- 3/8" Drive Ratchet
- 9/16" Socket
- 1/2" Socket
- 9/16" Wrench
- 1/2" Wrench



IMPORTANT NOTES:

Although our carriers can be assembled by one person, we highly recommend that you have a helper.

Since our carriers have a thick galvanized coating for years of longevity, some of the bolt holes may be too tight, due to the coating, to easily insert your bolts. This is easily remedied by lightly tapping the bolt into it's respective bolt hole. (See photo to right.)

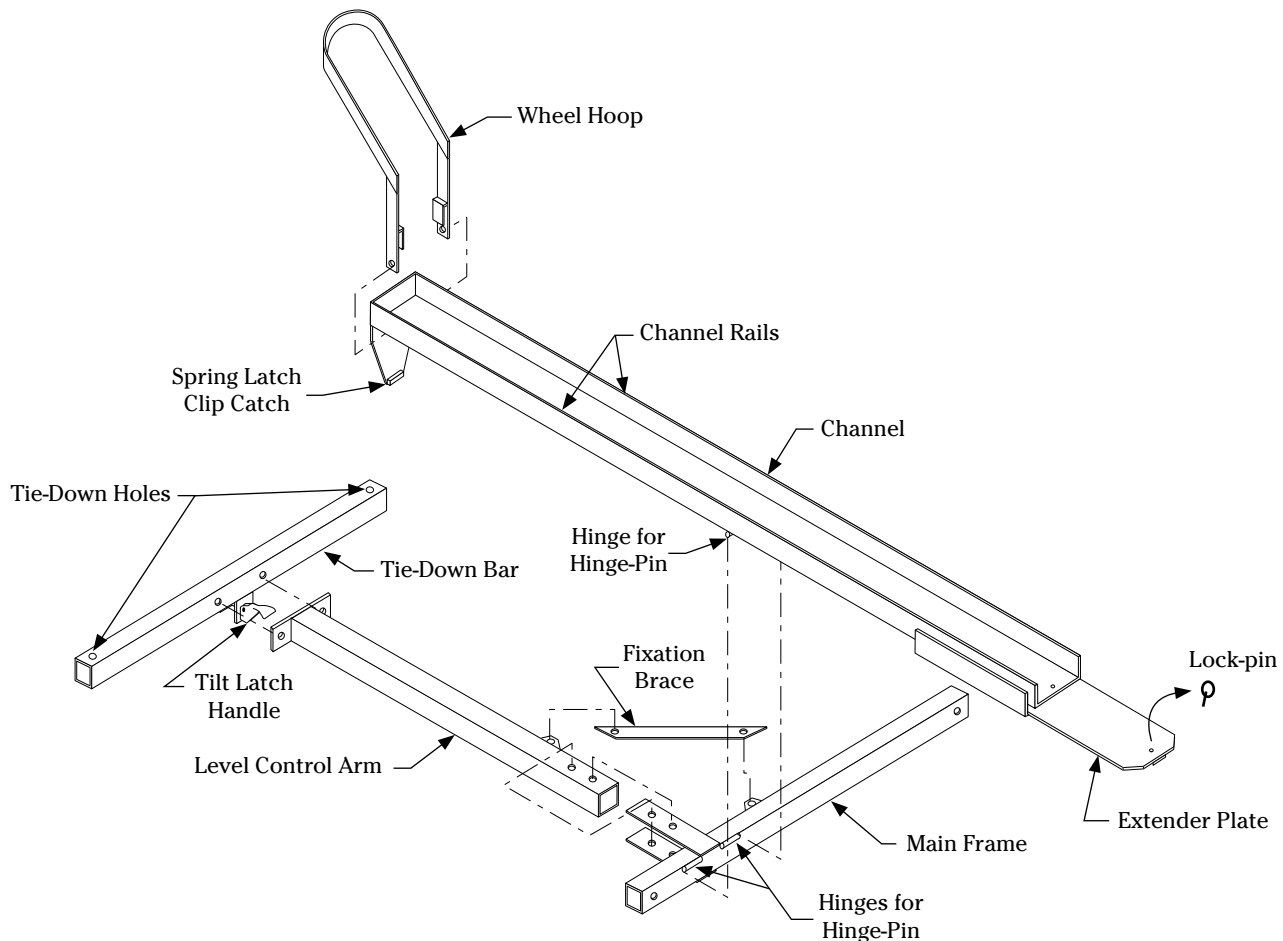

**IF YOU HAVE QUESTIONS REGARDING THE ASSEMBLY OF THIS UNIT,
OR HAVE MISSING PARTS, PLEASE CALL 1-866-777-9727.**

ATV Solutions also carries a wide selection of accessories for your new carrier!

Custom tie-downs, covers, hitch adapters, Bogie Wheels, and more, we've got what you need to **LOAD and GO!**

Go to www.ATVSolutions.com or call 1-866-777-9727 for more information.



STEP 1

Attach two 9/16" x 3" bolts through the Tie-Down Bar into the end of the Level Control Arm.



STEP 2

Secure the two pieces together using the self-locking nuts included.



STEP 3

Now attach the Main Frame to the Level Control Arm Assembly using the two remaining 9/16" x 3" bolts and self-locking nuts.



STEP 4

The end of your assembly should look like this. Make sure you put the nut on the bottom to allow clearance for the hinge plate located on the Channel.



STEP 5

Connect the Fixation Brace to the appropriate tabs on the Main Frame and Level Control Arm. See diagram on Page 1 for detailed location of tabs.

— Turn the carrier assemblies upside down for Steps 6 - 8. —

STEP 6

Locate the hinges on the Main Frame Assembly to the hinge on the bottom of the Channel.



STEP 7

Using a hammer, gently tap the Hinge-Pin into the Hinge. Oil may be used to help insert the pin. This area should also be lubricated if the carrier will not be used for an extended period.



STEP 8

With the Main Frame Assembly attached to the Channel, you can now secure it using the small black Roll-Pins provided. Make sure to not bend it when tapping it into its location.



STEP 9

Turn the assembly right-side up. Place the Wheel Hoop over the Channel Rails with the small tab inside the Channel Rails and the longer ends outside the Channel Rails.



STEP 10

Secure the Wheel Hoop to the Channel using the 9/16" x 6" bolt and self-locking nut provided. Insert onto your vehicle's receiver using your hitch-pin and your ready to LOAD and GO!



STEP 1

**OPERATING INSTRUCTIONS FOR TILT-A-RACK®
MODEL 410CR.**

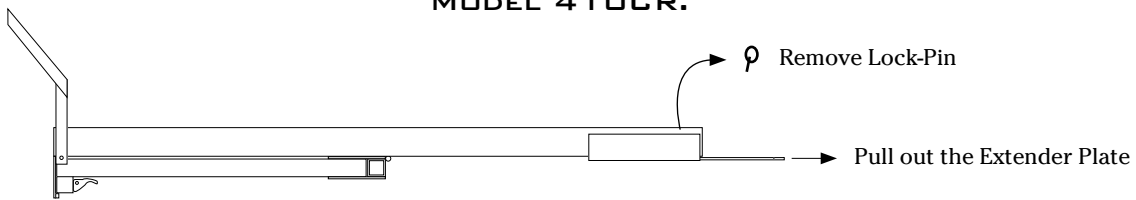

STEP 2

Release Tilt Latch and tilt the Channel until the Extender Plate rests on the ground

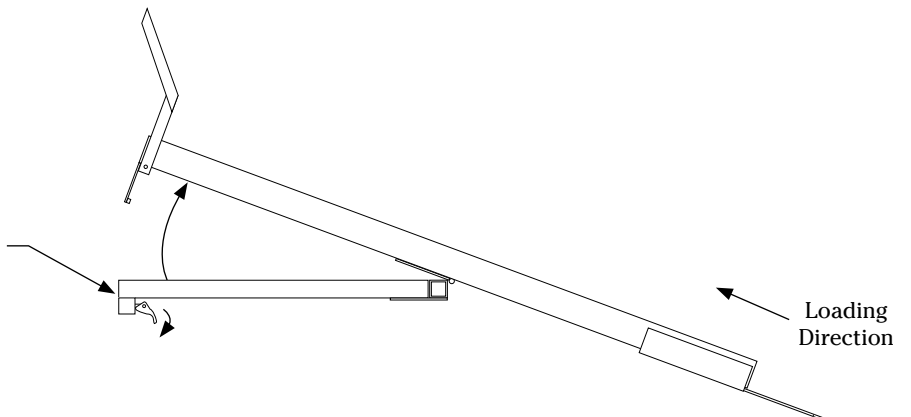

STEP 3 - LOAD YOUR UNIT AND GO!

**IF YOU HAVE QUESTIONS REGARDING THE ASSEMBLY OF THIS UNIT,
OR HAVE MISSING PARTS, PLEASE CALL 1-866-777-9727.**